

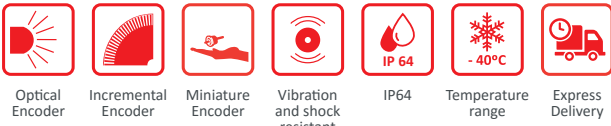

# SERIE 28

## MINIATURE BLIND HOLLOW SHAFT INCREMENTAL ENCODER FOR INDUSTRIAL APPLICATIONS

- Resolution up to 1.024 pulses per turn
- External diameter 24 mm
- Blind hollow shaft  $\varnothing$  4, 6 or 8 mm
- Protection class IP64 according to DIN EN 60529
- Shaft fixing through setscrew or clamp
- Anti-rotation system through flexible flange or pin torque support
- Connection by cable (other cable length available)



### Option A:

#### Setscrew / Anti-rotation pin (93.0108204)

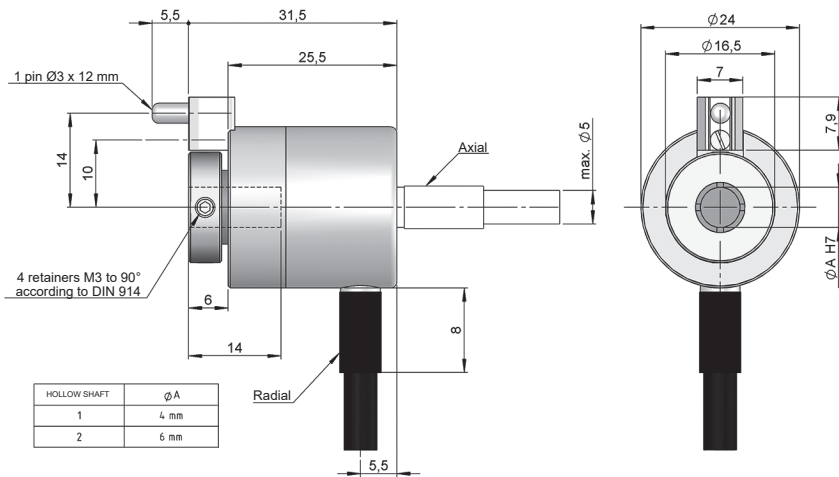

Drawing blind hollow shaft mechanical option type 2 (Anti-rotation pin 93.0108204, (pin included)), connection type 1/2

### Option B:

#### Clamp / Flexible flange (93.0102057)

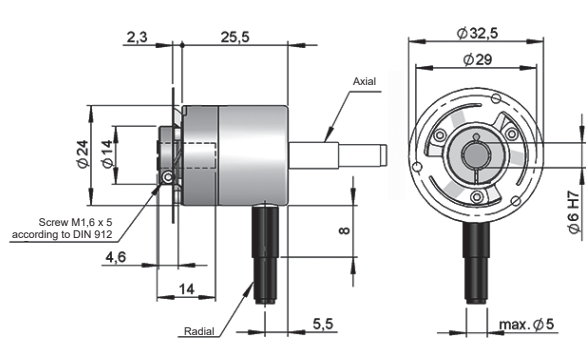

Drawing blind hollow shaft mechanical option type 3, connection type 1/2

### Option C:

#### Setscrew / Anti-rotation pin (93.0108201 + 93.0108202)

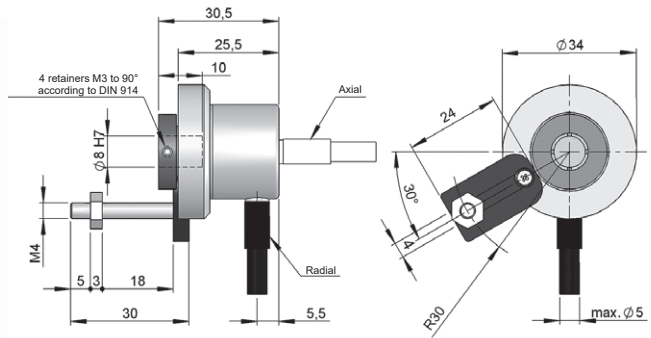

Drawing blind hollow shaft mechanical option type 4, connection type 1/2



# SERIE 28

## MINIATURE BLIND HOLLOW SHAFT INCREMENTAL ENCODER FOR INDUSTRIAL APPLICATIONS

### REFERENCE

Reference example : 28-1721-500

Serie	Mechanical option	Output signals	Connection	Power Supply / Electronic output	Pulses number	Special customer
28 -	<input type="checkbox"/>	<input type="checkbox"/>	<input type="checkbox"/>	<input type="checkbox"/> -	<input type="checkbox"/> <input type="checkbox"/> <input type="checkbox"/> <input type="checkbox"/>	<input type="checkbox"/> <input type="checkbox"/> <input type="checkbox"/> <input type="checkbox"/>
	<ol style="list-style-type: none"> <li>Option A - Ø 4 mm setscrew Anti-rotation pin (93.0108204)</li> <li>Option A - Ø 6 mm setscrew Anti-rotation pin (93.0108204)</li> <li>Option B - Ø 6 mm Clamp Flexible flange (93.0102057)</li> <li>Option C - Ø 8 mm setscrew Anti-rotation pin (93.0108201 + 93.0108202)</li> </ol>	<ol style="list-style-type: none"> <li>A+B</li> <li>A+B+0</li> <li>A<math>\tilde{A}</math>+B<math>\tilde{B}</math>+0<math>\tilde{0}</math></li> <li>A<math>\tilde{A}</math>+B<math>\tilde{B}</math></li> </ol>	<ol style="list-style-type: none"> <li>Axial cable</li> <li>Radial cable</li> </ol>	<ol style="list-style-type: none"> <li>11...30 VDC / NPN Open collector 11...30 VDC</li> <li>11...30 VDC / Line driver differential Push-Pull 11...30 VDC</li> <li>5 VDC / RS422 5 VDC (compatible TTL)</li> </ol>		<p>WT00. -40°C</p> <p><b>Order your reference Step file 3D</b></p> <p><a href="mailto:info@encoderhohner.com">info@encoderhohner.com</a> service available in 24 h</p>

### MECHANICAL SPECIFICATIONS

Materials	Cover: Aluminium Housing: Aluminium Shaft: Brass
Bearings	Ballraces
Bearings lifetime	1x10 <sup>10</sup> rev.
Housing fixing	Anti-rotation pin or flexible flange (included)
Shaft fixing	Setscrew or Clamp
Blind hollow shaft diameter	4, 6 or 8 mm
Maximum number of revolutions permitted mechanically	6000 rpm
Protection against dust and splashes according to DIN EN 60529	IP64
Rotor inertia moment	1 gcm <sup>2</sup>
Starting torque at 20°C (68°F)	≤ 0,01 Nm
Maximum load permitted on axial shaft	10 N
Maximum load permitted on radial shaft	10 N
Weight aprox.	0,06 Kg
Operating temperature range	-20°C to +80°C - Standard -40°C to +80°C - Special Customer WT00
Vibration according to DIN EN 60068-2-6	100 m/s <sup>2</sup> (10Hz...2000Hz)
Shock according to DIN EN 60068-2-27	1000 m/s <sup>2</sup> (6ms)
Maximum pulses per turn	1.024
Axial or radial connection	2 meters cable (other cable lengths available or connector mounted at the end of the cable, upon request)

# SERIE 28

## MINIATURE BLIND HOLLOW SHAFT INCREMENTAL ENCODER FOR INDUSTRIAL APPLICATIONS

### OUTPUT SIGNALS

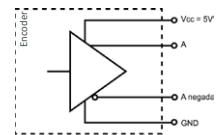
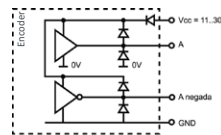
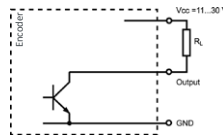

OUTPUT CIRCUIT	NPN Open Collector	Push-Pull Differential	RS422 (TTL compatible)
Reference code	0	1	2
Power supply	11...30 VDC	11...30 VDC	5 VDC ±5%
Output voltage	11...30 VDC	11...30 VDC	5 VDC
Consumption	40 mA	Typical: 45 mA Max: 150 mA	Typical: 70 mA Max: 150 mA
Max. load capability / channel	40 mA	±30 mA	±20 mA
Length of cable allowed	50 m (24 VDC)	100 m	1200 m
"Low" signal level	VOL < 0.4 VDC (24 VDC)	VOL < 2.5 VDC	VOL < 0.5 VDC
"High" signal level	VOH > 22 VDC (24 VDC)	VOH > VCC – 3 VDC	VOH > 2.5 VDC
Frequency	100 kHz	200 kHz	300 kHz
Short circuit protection	Not permanent	Yes	Yes
Protection polarity inversion	Yes	Yes	No

Channel A leads (90° electric) channel B, view from the shaft, shaft rotating clockwise

### CONNECTION



	95.0008051 (* Cable 5x0,14)	95.0008052 (* Cable 8x0,14)
GND	White	White
VCC	Brown	Brown
A	Green	Green
B	Yellow	Grey
~A		Yellow
~B		Pink
0 (reference)	Grey	Blue
~0	Grey	Red

(\* For lengths over 2 meters standard cable, we recommend the use of twisted pair cable 2x2x0,14+1x0,14 (95.0008002) or 3x2x0,14+2x0,34 (95.0008003). Request the final cable length required to avoid junctions.

# SERIE 28

## MINIATURE BLIND HOLLOW SHAFT INCREMENTAL ENCODER FOR INDUSTRIAL APPLICATIONS

### ACCESSORIES EXAMPLES

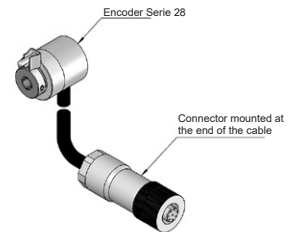
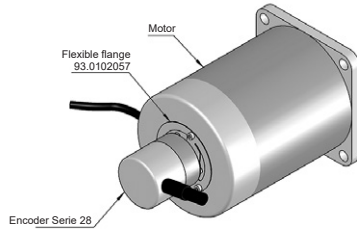
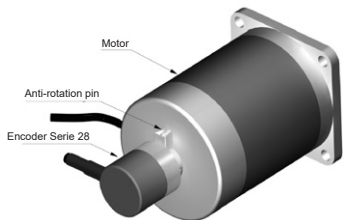

All the accessories available in the section "MOUNTING ACCESSORIES".